



INSTALLATION INSTRUCTIONS

Accessory
FULL NOSE MASK
P/N 08P35-STX-200A

Application
2012 MDX

Publications No.
BII 46620
Issue Date
OCT 2011

Put this information in the glove box with the vehicle owner's manual.

PARTS LIST

Bumper section

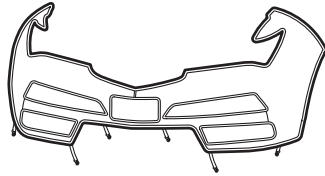

Hood section



2 Snap-screws

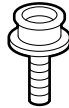

2 Washers



2 Fenderwell nuts



Storage bag

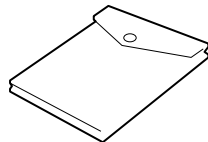

TOOLS AND SUPPLIES REQUIRED

Stubby Phillips screwdriver
Flat-tip screwdriver
Scissors
High-quality paste wax

INSTALLATION

NOTE:

- Make sure the vehicle and the nose mask are clean and completely dry before installation. If moisture under the mask is allowed to dry, it may cloud the paint. If the mask gets wet, remove it and allow it to air-dry completely.
- Make sure any repainted surfaces are cured.
- Wax the hood and nose of the vehicle with a high-quality paste wax.
- Install the nose mask securely. If the nose mask starts to flap or comes loose while driving, safely pull off the highway, stop the vehicle, and secure or remove the mask.
- The nose mask cannot be installed if the vehicle is equipped with fenderwell trim, front lower trim, or an air deflector.

Displaying the License Plate

If your state law requires the display of both license plates, cut out the piece of the mask's bumper section that covers the front license plate:

- Face the inside of the bumper section toward you.
- Carefully cut out the license plate section with scissors at the top seam, and remove the overcast stitching.

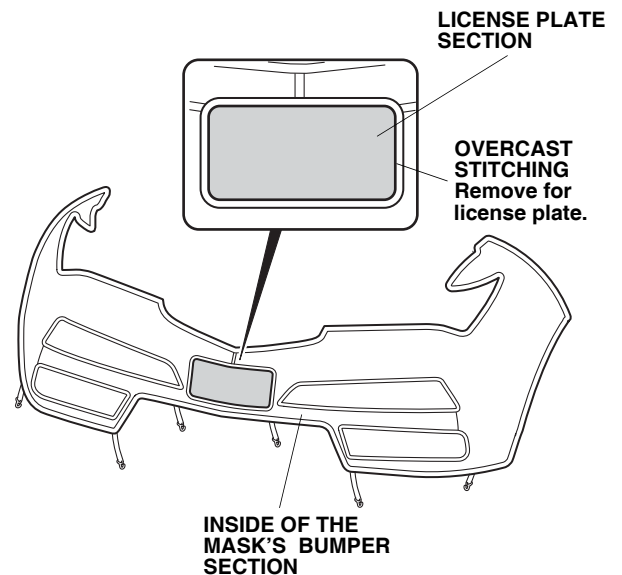

Installing the Hood Section

1. Open the hood. Fit the corners of the mask's hood section around the hood, and adjust it so it fits smoothly over the edges. Attach the five S-hooks to the holes in the hood.

NOTE: Make sure the flap along the top edge is not folded under.

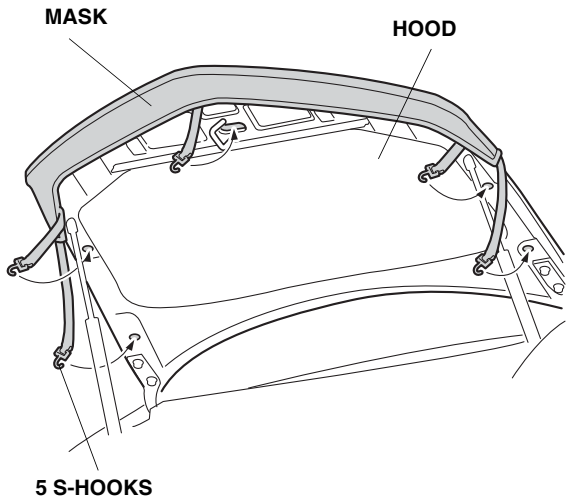

Installing the Bumper Section

2. Turn the steering wheel all the way clockwise.

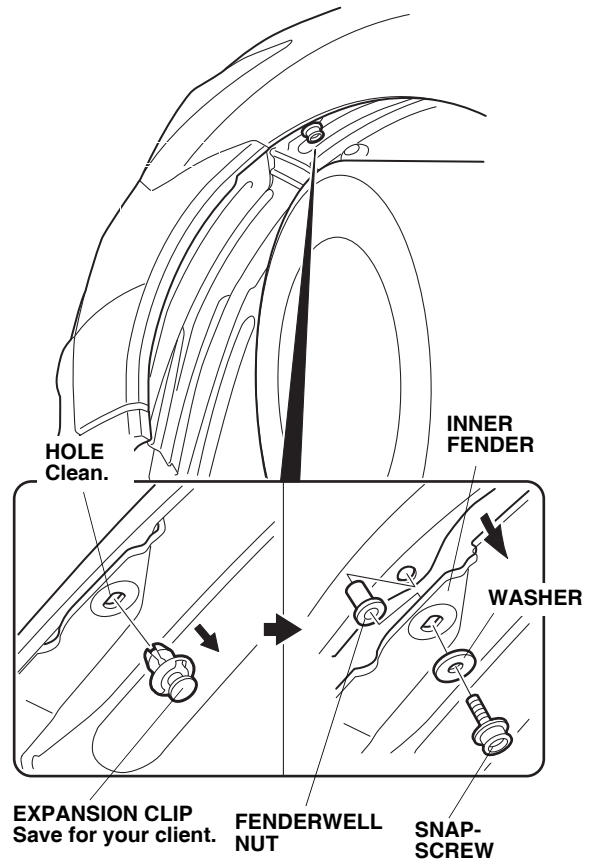

3. On the left side of the vehicle, remove the expansion clip that fastens the inner fender. Retain the expansion clip. Clean the area around the hole.
4. Pull back the inner fender, and press one fenderwell nut into the hole in the fender flange.
5. With a washer in place, securely tighten one snap-screw into the fenderwell nut.
6. Turn the steering wheel all the way counterclockwise, and repeat steps 3 through 5 on the right side of the vehicle.

- Slip the pocket on the mask's fender section onto the front corner of the fender, then attach the plastic hook to the top inside edge of the fender. Fit the mask across the front bumper, and attach it to the other side in the same way.

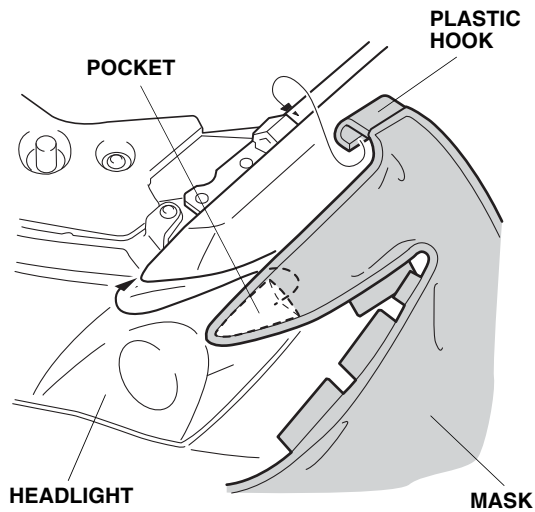

- Attach the four S-hooks to the bottom edge of the front bumper.

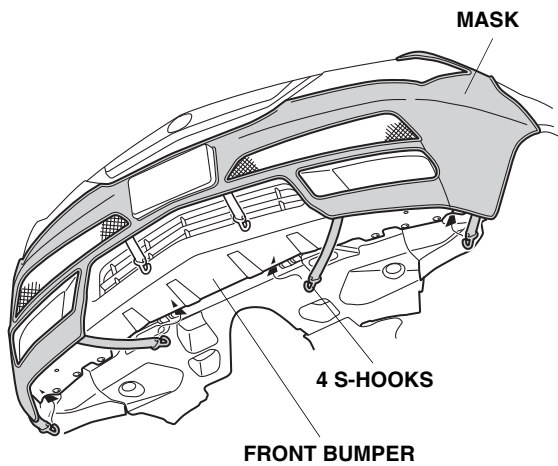

- Attach the two S-hooks to the inside edge of the lower grille opening.

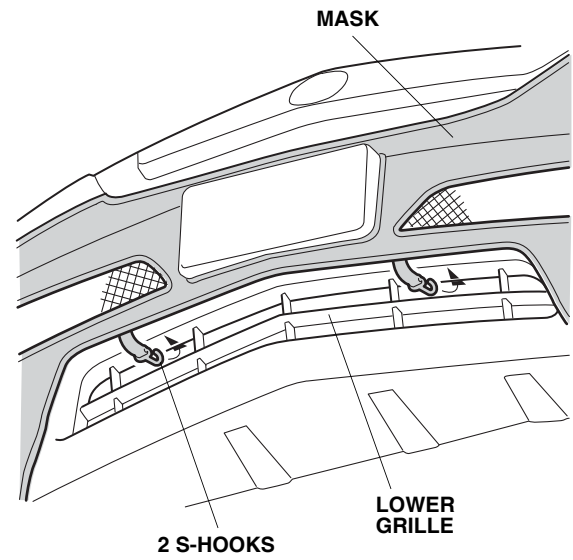

- Pull the mask back toward the wheelwell, smooth out any wrinkles, and then snap the mask onto the snap-screw. Attach the three plastic hooks on the mask to the edge of the front bumper. Repeat on the other side.

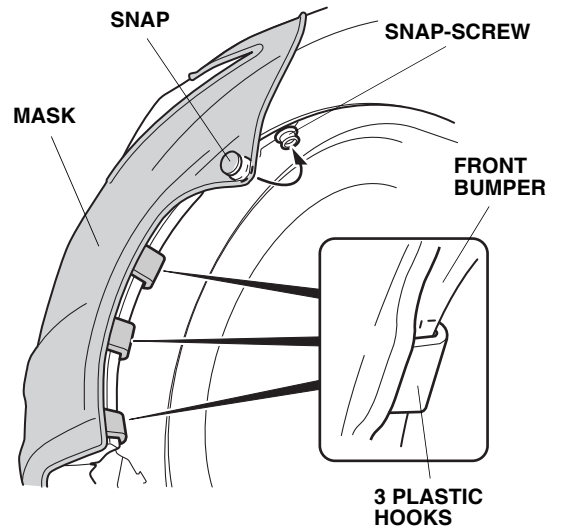

11. Insert the two tabs between the license plate base and the front bumper.

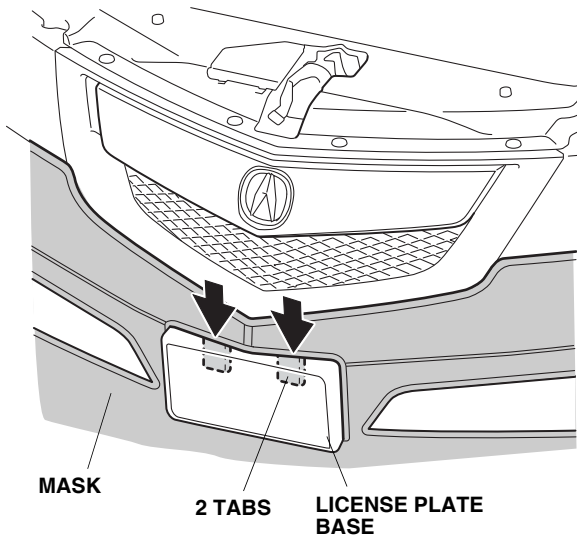

12. On each side of the vehicle, insert the seven tabs between the headlight and the front bumper.

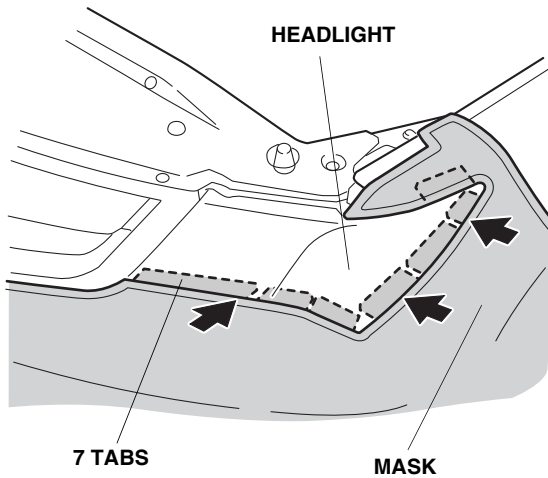

13. Put the expansion clips (removed in step 3) into the storage bag, and place it in the cargo area for future use.

CLEANING THE NOSE MASK

Use a sponge or cloth and a solution of mild liquid dishwashing soap and water to clean the vinyl and the flannel backing. Rinse the mask completely with clean water, and hang it to dry, out of direct sunlight. Make sure the mask is completely dry before you reinstall it.